



Version:2010-2

# OWNER'S MANUAL

FOR  
**BEAUTY-MARK®**  
**Retractable Awnings**

**MAUI®** model  
**DESTIN®** model

**Manual and Motorized Awnings**



**Do not leave the awning extended during extreme weather conditions such as wind, rain, snow and ice. The extreme weather conditions may cause the arms to break and can cause damage personal or injury to the property. Awntech does not take any responsibility for any weather related or improper handling damages.**

# Table of Contents

<b>PAGE</b>	<b>SECTION</b>
3	Time required installing the awning
3	Parts
3	Required tools
4	Exploded view of the awning
5	Types of brackets
6-10	Determining bracket placements
11-19	Installation instructions for various surfaces
20	Installing the awning on the brackets
21	Adjusting the pitch
22-23	Conversion of the manual awning to motorized
24	Introduction to remote control
25-26	Limit control adjustments
27	Hood assembly and installation (see the revised)
28	Installing the pitch adjustment system
29	Installing the breeze support legs
30	Installing the center support bracket
31	Replacing the awning fabric
31	Replacing the valance
32	Replacing the arms
33	Warranty
34	Returns, Damages
35	Determining awning size and placing an order
36-37	Frequently asked questions
38	Risks, Warnings, and Warranty
39	Cleaning and caring
40	Technical specifications
41	Fabric specifications

# IMPORTANT: THE RETRACTABLE AWNINGS ARE NOT DESIGNED TO LEAVE OPEN DURING HIGH WINDS, RAIN, SNOW OR ICY CONDITIONS.

*Do not leave the awning extended during extreme weather conditions such as wind, rain, snow and ice. The extreme weather conditions may cause the arms to break and can cause damage personal or injury to the property. Awntech does not take any responsibility for any weather related or improper handling damages.*

Congratulations and thank you for your purchase of the Beauty-Mark® Retractable Awning by Awntech! We at Awntech, wish your family and friends many enjoyable experiences with it. As you can see, the awning is fully assembled, so all you need to do is install the brackets, place and secure the awning on them, make some adjustments ...and enjoy!

**BEFORE YOU START:** Please read instructions completely prior to attempting installation. Damage to awning during the installation is not covered by the warranty. After reading, if you feel that you will need further installation assistance, please contact a local contractor for professional installation.

## TIME REQUIRED FOR INSTALLATION:

Between 1-3 hours

## INCLUDED PARTS:

- Beauty-Mark® Awning (completely assembled including fabric)
- 2-6 Wall Mounting Brackets (see chart below)
- Rocker Arm or Crank Handle
- Owner's Manual

Width of Awning	# of Brackets
8 ft. – 10 ft.	2
12 ft. – 14 ft.	3
16 ft. – 18 ft.	4
18 ft. – 20 ft.	5
24 ft.	6

## REQUIRED ITEMS:

- Drill
- Full wood/metal and masonry bit sets (3/8 shank-1/2 bit masonry bit for masonry applications)
- 2-3 16' Extension Ladders
- Stud Finder
- Full ratchet and socket set
- Screwdriver set
- String level
- Tape Measure
- Chalk line

- An Assistant (two, if awning is more than 12' long)

## SEE THE FOLLOWING APPLICATIONS FOR SPECIFIC SIZES OF TOOLS AND HARDWARE REQUIREMENTS

**NOTE:** There are many different building configurations and surfaces on which to mount your Beauty-Mark® Retractable Awning. AWNTECH provides the most common of these: **WALL MOUNTING BRACKETS** in its standard packaging. Because there are so many building surfaces, Awntech does not provide mounting bolts and hardware. Read carefully to determine whether you need another type of bracket and read the follow sheets to determine the types and sizes of screws, bolts, anchors, lumber and tubing you may need to purchase for your specific needs.

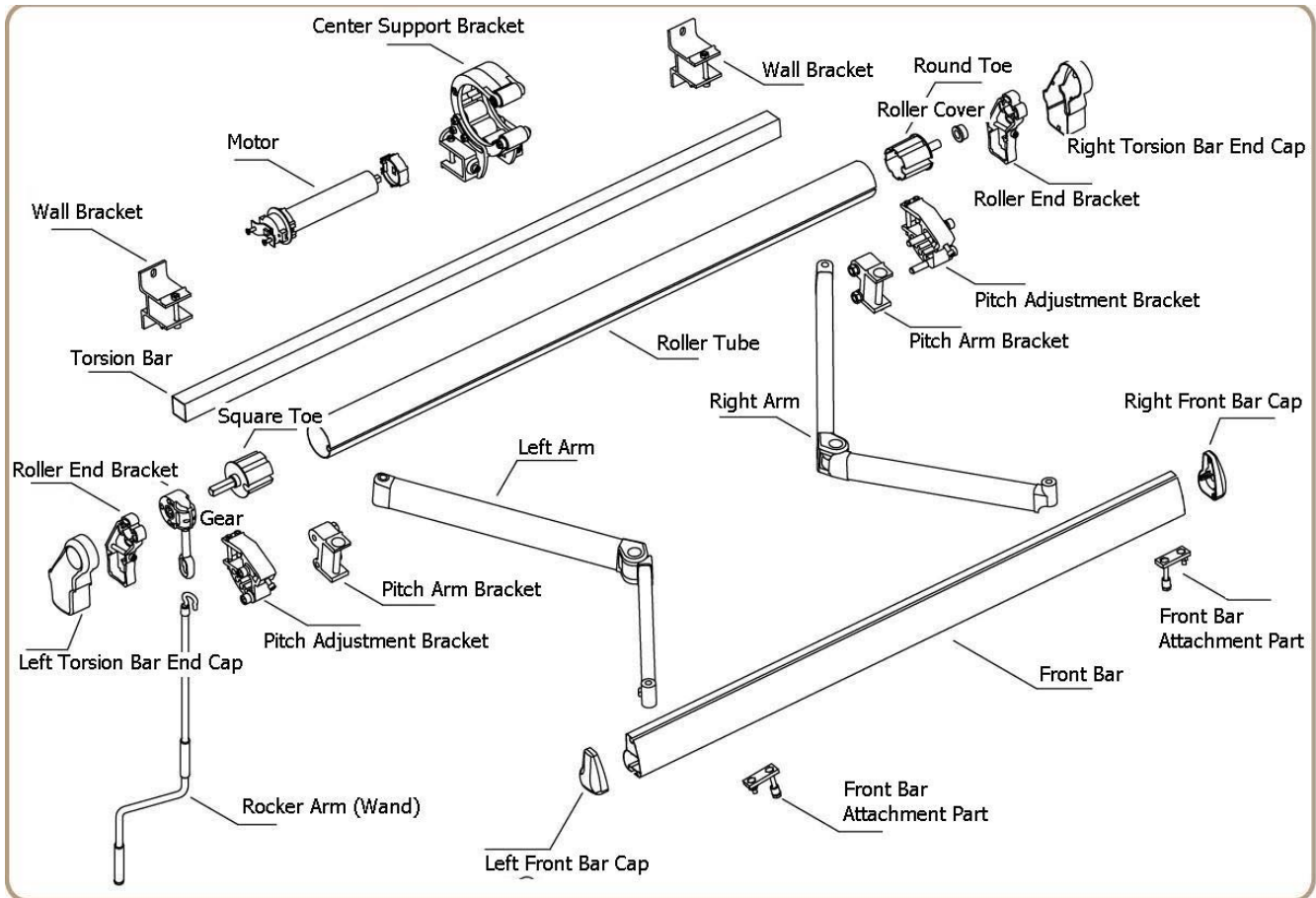

# TYPES OF MOUNTING BRACKETS

1. **Wall Mounting Brackets** These are the most commonly used brackets. They are included with all awnings. This bracket is designed for any flat exterior wall mounting surface with a horizontal band at least 10" tall, at least 8'-0" from the eave to the surface of the patio. It can also be mounted on a fascia (with guttering removed) higher than 7'-0" and lower than 9'6" from the patio to the bottom of the fascia.

Wall Bracket Measurements:		Soffit Bracket Measurements:		Roof Bracket Measurements:	
Height	5.5"	Height	8"	Height	9"
Width	2.25"	Width	1 7/8"	Width	3"
Depth	3"	Depth	4 5/8"	Depth	9"
Between the holes	3.75"	Between the holes (top)	2 3/4"	Between the holes (Base)	2 3/8"-2 3/8"-1.1/4"
		Between the holes (back)	3"	(Front to back)	

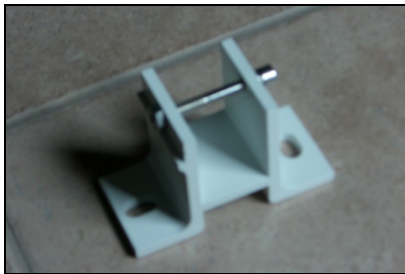

Wall Bracket



Eave or Soffit Bracket

(Optional and can be purchased separately)

2. **Eave Mounting Brackets (optional)** This bracket is designed for any application where there is not a 10" tall horizontal vertical band to mount the awning to, and there is an eave (or bottom of a beam) higher than 7'-9" and lower than 10'-2" from the surface of the patio to the bottom of the eave. The eave (or bottom of the beam) must be at least 5" wide. It is also an effective tool if eaves are deep and you want to maximize the projection of your awning. NOTE: DO NOT PURCHASE SOFFIT BRACKETS WITH A DESTIN. It may be purchased by calling Awntech at 800-203-7049 or sending an email to sales@awntech.com.
3. **Roof Mounting Brackets (optional)** this bracket is designed for any application where the wall mounting and eave mounting brackets conditions are either not met or not acceptable and a roof mounting application is desired. It is only designed for composition roofs on wafer board or plywood decking. (At this time, we have no solution for clay tile, slate, or cedar shake applications over lath.) NOTE: WE HIGHLY RECOMMEND THE PURCHASE OF A MOTOR FOR THIS APPLICATION. Awntech highly recommends that a professional roofing contractor to do the installation. It may be purchased by calling Awntech at 800-203-7049 or sending an email to sales@awntech.com.



(Optional and can be purchased separately)

# INSTALLING BRACKETS

PLACEMENT OF THE BRACKETS IN THE OPTIMUM LOCATION WILL GREATLY AFFECT YOUR LONG TERM HAPPINESS WITH YOUR AWNING. BELOW YOU WILL FIND A PLACEMENT GUIDE.

## DETERMINING BRACKET PLACEMENT:

FOR STARTERS: A DESTIN IS A MAUI WITH A HOOD AND A MOTOR. THE HOOD MAKES THE AWNING TALLER, SO OUR DIAGRAMS SHOW DIMENSIONS FOR BOTH STYLES.

**Please refer to the following drawings on pages 7-10 to determine your particular mounting bracket needs.**

If A most closely reflects your application, this requires wall brackets which are included with your awning.

If B or C most closely reflect your desired application, this requires that you purchase one eave bracket to replace each wall bracket required.

If D most closely reflects your desired application you will need wall brackets for both applications (which come with your awning, however, if you choose a roof mounted application you must purchase one roof bracket per wall bracket required.

- You must center and secure your brackets into the center of studs or rafters. These are hidden from view behind your wall surfaces or roof surface. A stud finder is a tool that finds nails with an internal magnet. Nails are an indicator of where studs and rafters are, but not a guarantee. It is extremely important that you test your conclusions. Nails will be found in vertical lines. Fully install a bolt in the location where you have concluded your stud or rafter is located; If at any time it becomes easy to turn the ratchet, you ARE NOT in the stud or rafter. For guide purposes only: most studs and rafters are 12", 16" or 24" apart.
- Mark all the locations of the studs or rafters in the area where you have decided to install your awning.
- There should be one bracket within one feet of each end or close to the lateral arms and then distribute the rest of the bracket(s) evenly spaced across the awning torsion bar. Choose the appropriate studs or rafters to install your brackets onto. Hint: short studs above windows and doors are structural and may be used to secure bracket as well as full length studs.

# (A)

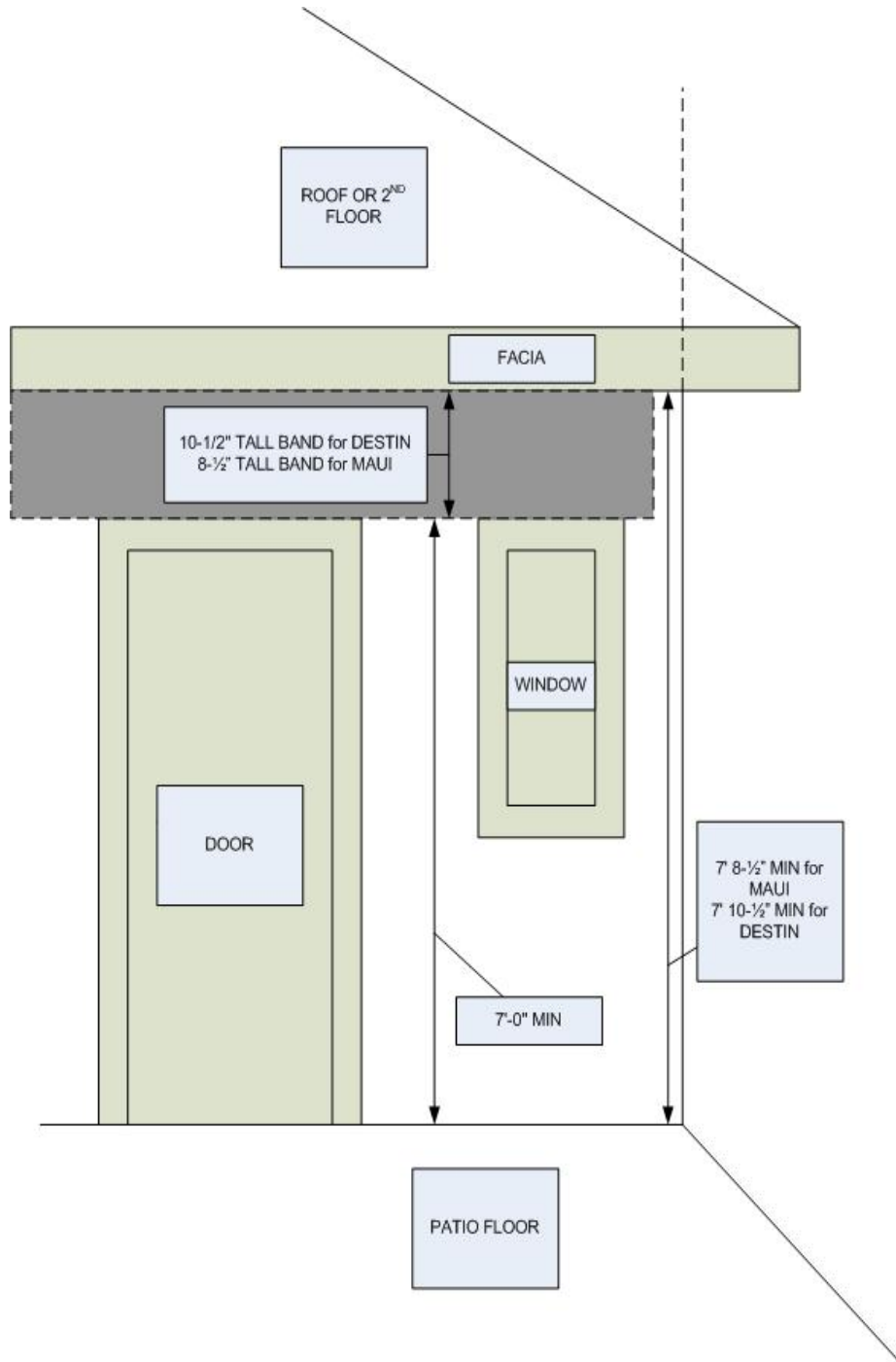

# (B)

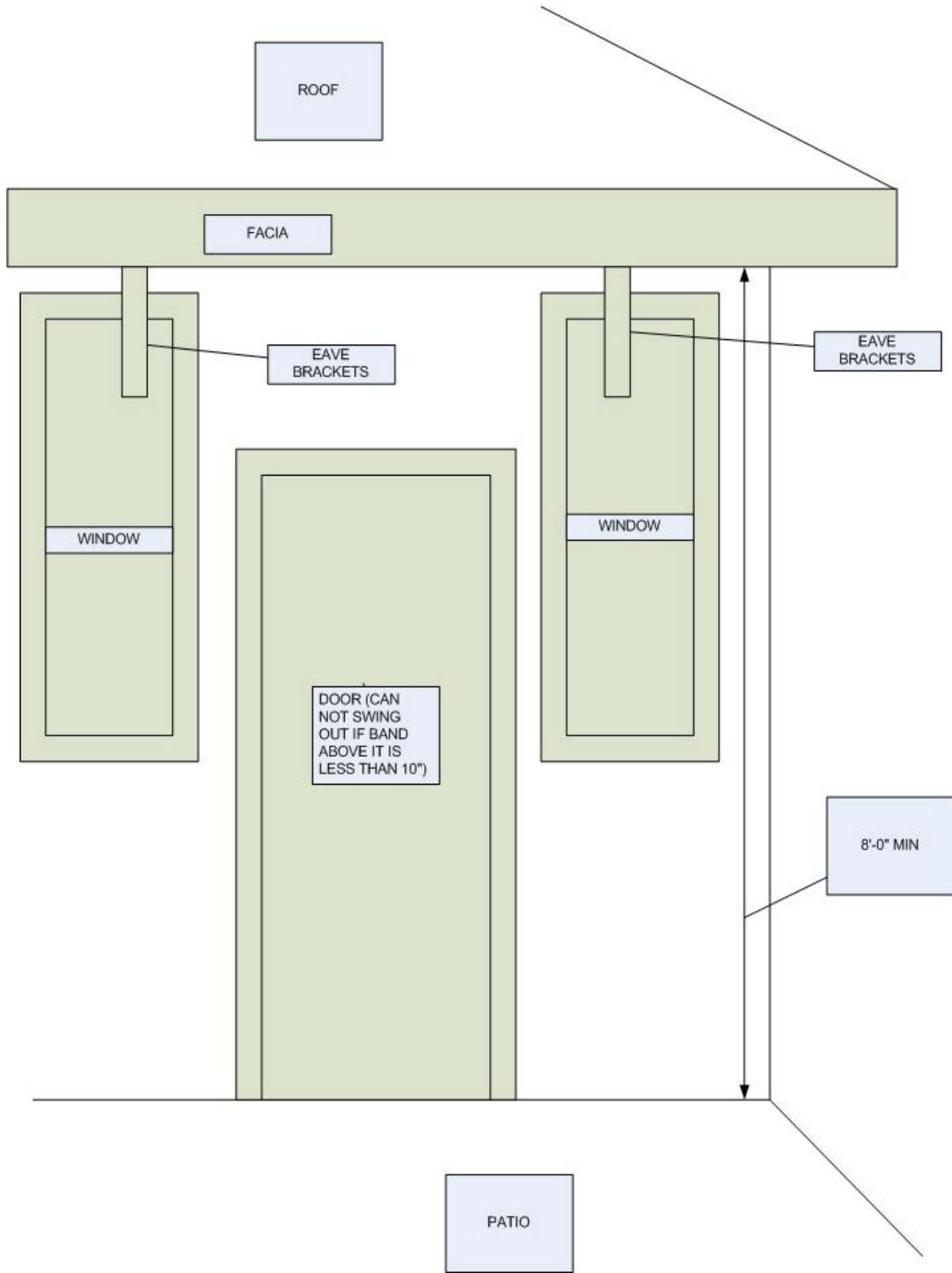

(C)

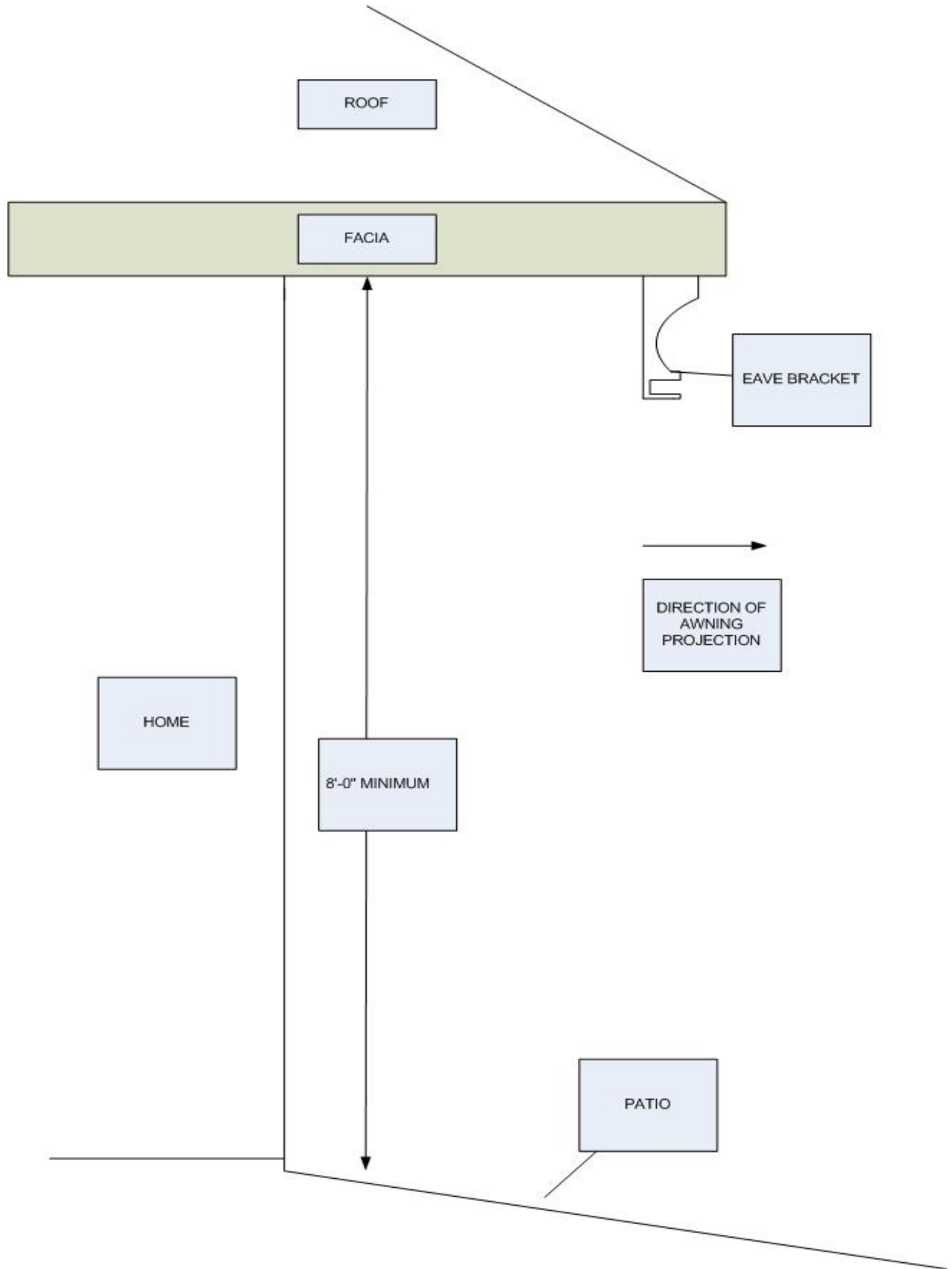

(D)

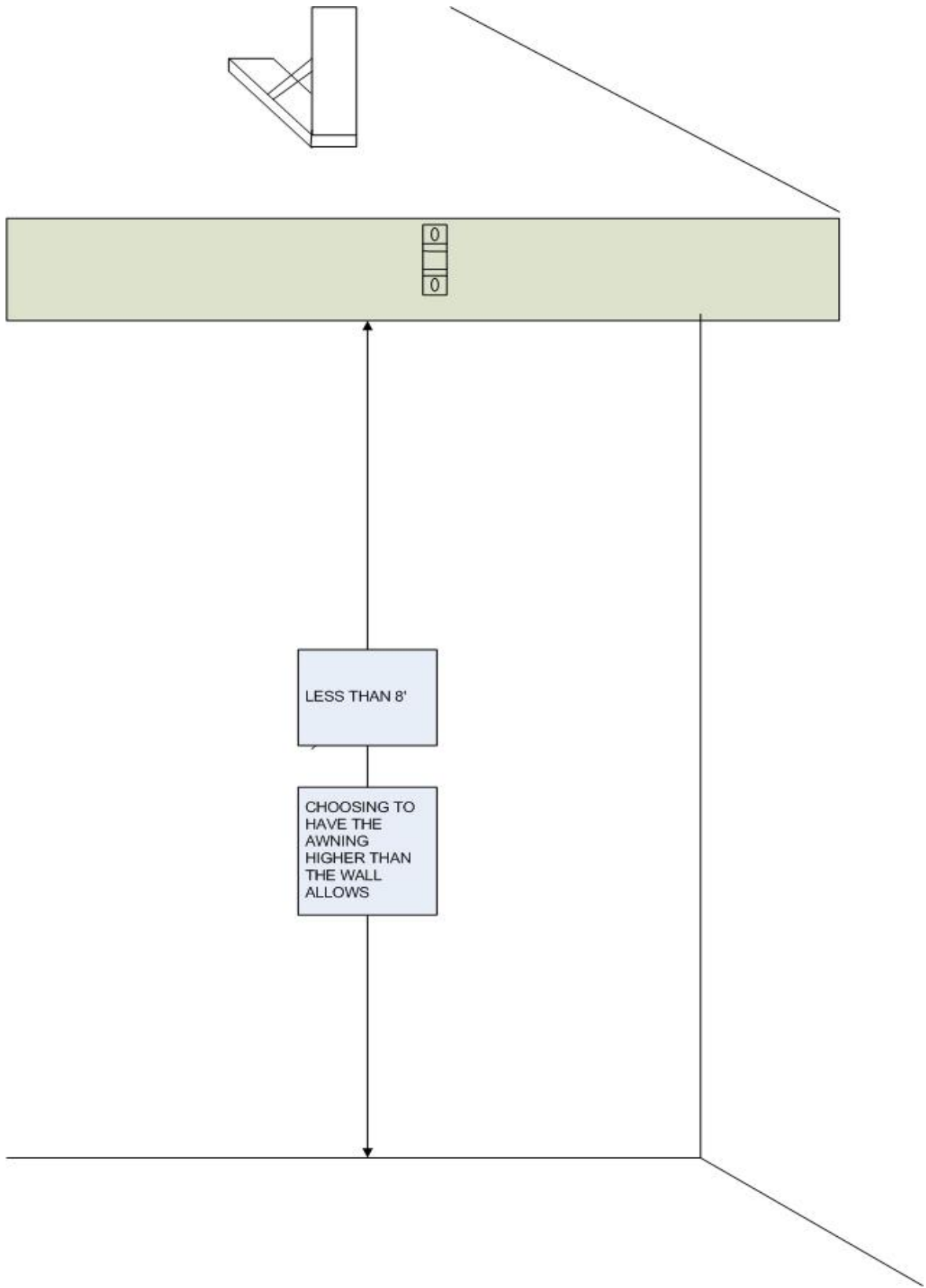

**TO HELP YOU VISUALIZE WHAT IS BEHIND THE WALLS AND ROOF, AND TO DEFINE TERMINOLOGY, WE HAVE PROVIDED THE FOLLOWING ILLUSTRATIONS**

**TYPICAL DETAIL OF ROOF FRAMING**

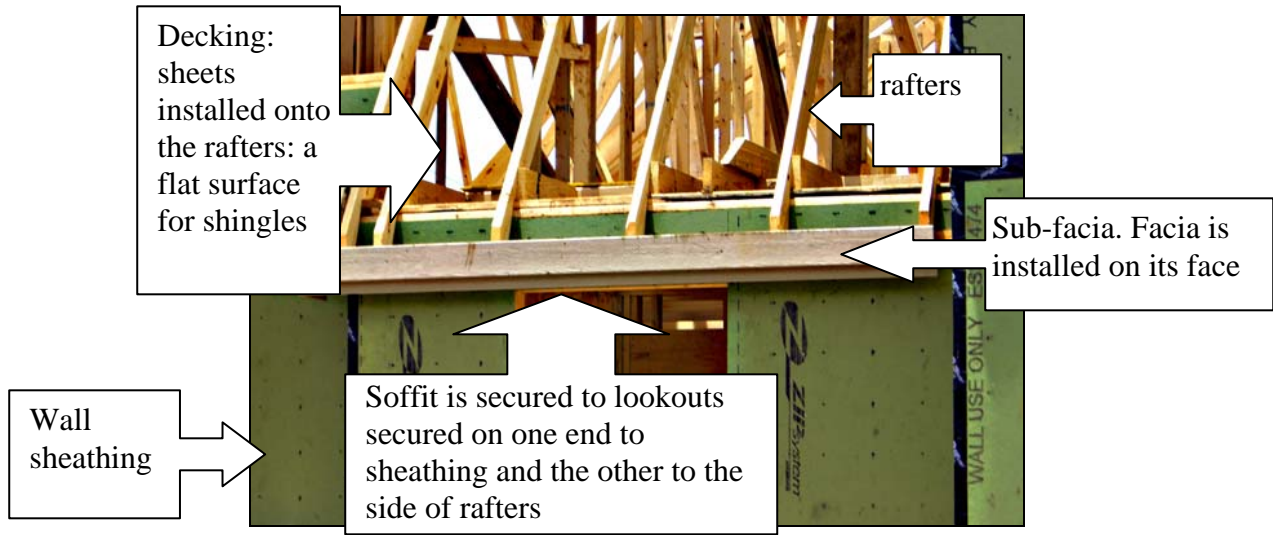

**TYPICAL DETAIL OF THE STUDS INSIDE THE WALLS (INTERIOR VIEW)**

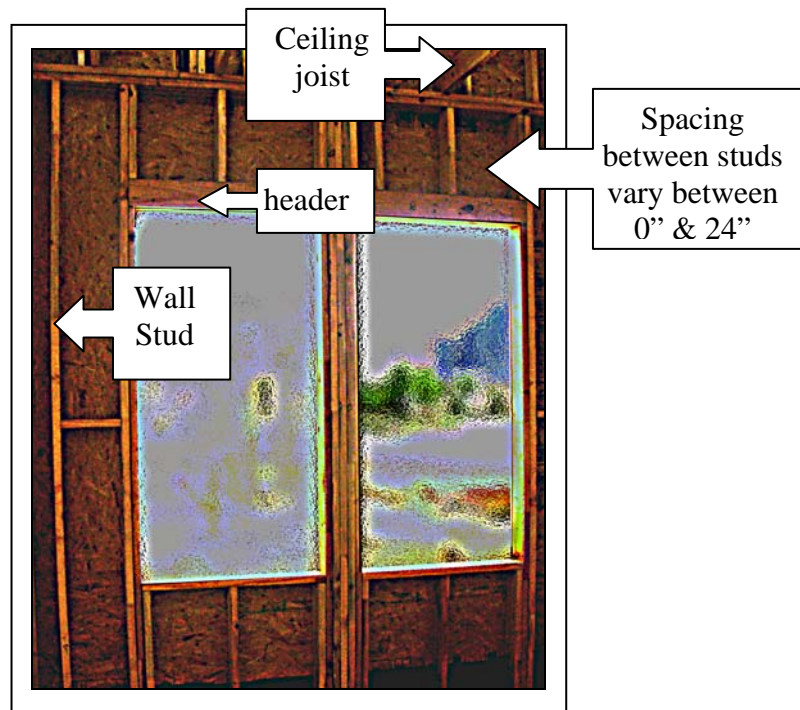

## THE FOLLOWING PAGES ARE INSTRUCTIONS FOR THE MOST COMMON INSTALLATION APPLICATIONS

### APPLICATION A

#### INSTALLING WALL MOUNTING BRACKETS TO FLAT SIDING, STUCCO, CEMENT OR CULTURED STONE (OF ANY TYPE):

- Place a safe ladder on a flat, dry, stable surface at both ends of where the awning will be installed
- Using a chalk-line and a string level (or a laser level) mark a horizontal line at your chosen height above the patio.
- Using a stud finder, mark the center of all the studs along the line where the awning will be installed. Failure to center bolts in structural studs will cause premature failure and result in awning collapse and possible injury.
- Mark both ends of where the awning will be installed on that line.
- There should be one bracket within one feet of each end or close to the lateral arms and then distribute the rest of the bracket(s) evenly spaced across the awning torsion bar. Choose and mark the best studs to install the brackets on given those requirements.
- Cultured stone surfaces may require a grinder to flatten off the area where the brackets are to be installed
- Using the bracket as a template (the top of the bracket has a ridge on it), mark the holes. Place the bottom of the bracket on the chalk line. **BRACKETS WILL BE THE LOWEST POINT OF THE AWNING.**
- For stucco or cultured stone: Use a 5/16" masonry bit to get through the surface. Drill a pilot hole into the stud beyond it with a 3/16" wood/metal bit. For wood, cement or hardboard surfaces drill a pilot hole into the stud with a 3/16" wood/metal bit. Using a ratchet, install (2) 5/16"x3" lag screws and (2) 5/16" washers to secure the bracket to the wall.
- For concrete surfaces: Use a 5/16" masonry bit to drill 3" deep holes into the surface. Insert two 5/16"x3" wedge anchors into the hole. Install a washer on each anchor. Place the bracket so the anchors come through the mounting holes. Install another washer and fully tighten the nuts.
- For flat siding: The easiest way is to mount a 1" x 5"- 6" treated/painted timber beam (the same length as your awning width) through the siding into the studs using (2) 5/16"x3" lag screws and (2) 5/16" washers. Then you mount the awning to the studs through the timber beam. Or mount a 2" x 5"- 6" treated/painted timber beam (the same length as your awning width) through the siding into the studs.
- Repeat the process for the remaining brackets.
- Seal around each bracket with a clear paint-able silicone caulking.

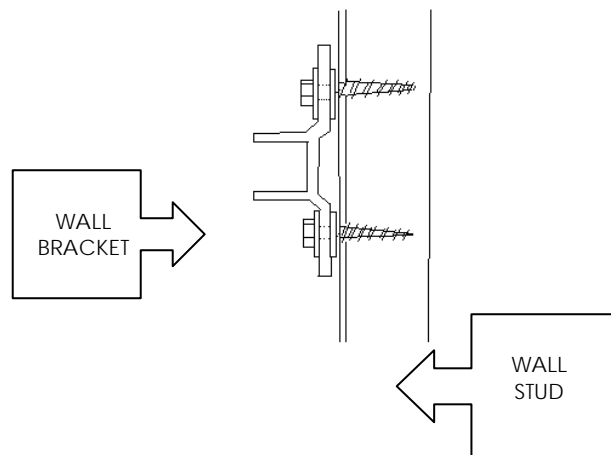

## APPLICATION B

### INSTALLING WALL MOUNTING BRACKETS TO ALUMINUM, VINYL, HARDBOARD OR LAP SIDING

- Place a safe ladder on a flat, dry, stable surface at both ends of where the awning will be installed
- Using a chalk-line and a string level (or a laser level) mark a horizontal line at your chosen height above the patio.
- Using a stud finder, mark the center of all the studs along the line where the awning will be installed. Failure to center bolts in structural studs will cause premature failure and result in awning collapse and possible injury.
- Mark both ends of where the awning will be installed on that line.
- There should be one bracket within one feet of each end or close to the lateral arms and then distribute the rest of the bracket(s) evenly spaced across the awning torsion bar. Choose and mark the best studs to install the brackets on given those requirements.
- Using the bracket as a template, mark the holes. Place the bottom of the bracket on the chalk line
- For aluminum or vinyl: Mark a 5-1/2"x5-1/2" square (centered on the stud left to right and on the bracket vertically) where the bracket will be placed. Cut the siding with a sharp utility knife.
- For all other siding: Mark a 5-1/2"x5-1/2" square (centered on the stud left to right and on the bracket vertically) where the bracket will be placed. Cut the siding with a circular saw set at the depth of the siding. Corners may need trimmed with a hammer and a sharp chisel.
- Make the appropriate number of 5-1/2"x5-1/2" wood blocks made from a piece of 2x6 lumber.
- Using the brackets as a template (the top of the bracket has a ridge on it), drill (2) 5/16" holes in the blocks. Sand the corners and paint the blocks to match your exterior paint color.
- Drill a pilot hole into the stud with a 3/16" wood/metal bit.
- Using a ratchet, install (2) 5/16"x4-1/2" lag screws (9/16" socket) and (2) 5/16" washers to secure the bracket to the stud behind the block.
- Seal around each block with clear paint-able silicone caulking.
- Repeat the process for the remaining brackets.

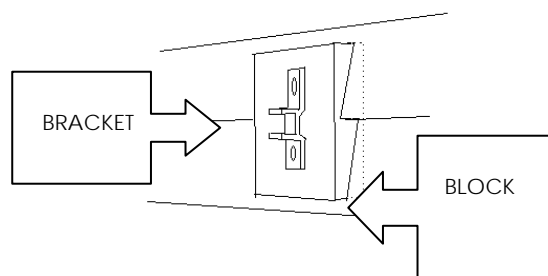

## APPLICATION C

### INSTALLING WALL MOUNTING BRACKETS TO FASCIA

**CAUTION: BEFORE INSTALLING BRACKETS ON FASCIA ALL GUTTERING MUST BE REMOVED. AWNING CAN NOT BE INSTALLED ON THE FASCIA IF THE FASCIA BOARD IS LESS THAN 5" HIGH. TOP OF THE AWNING WILL STAY ABOVE THE ROOF LINE SINCE THE MOUNTING BRACKETS ARE THE LOWEST POINT OF THE AWNING.**

- Place a safe ladder on a flat, dry, stable surface at both ends of where the awning will be installed
- Using a chalk-line and a string level (or a laser level) mark a horizontal line, one inch above the bottom edge of the fascia
- Using a stud finder, mark the center of all the rafters along the line where the awning will be installed. Failure to center bolts in structural rafters will cause premature failure and result in awning collapse and possible injury.
- Mark both ends of where the awning will be installed on that line.
- There should be one bracket within with in one feet of each end or close to the lateral arms and then distribute the rest of the bracket(s) evenly spaced across the awning torsion bar. Choose and mark the best studs to install the brackets on given those requirements.
- Using the bracket as a template (the top of the bracket has a ridge on it), mark the holes. Place the bottom of the bracket on the chalk line.
- Drill a pilot hole into the rafter with a 3/16" wood/metal bit. Using a ratchet, install (2) 5/16"x5" lag screws (9/16" socket) and (2) 5/16" washers to secure the bracket to the fascia.
- Repeat the process for the remaining brackets.

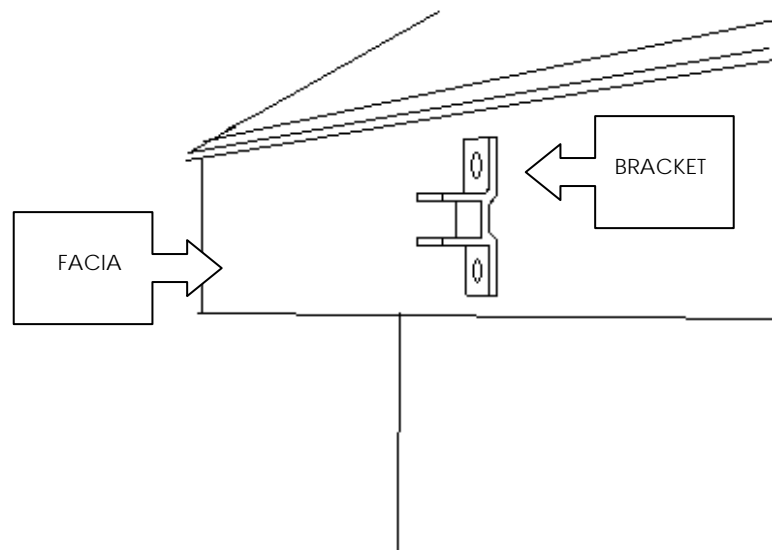

## APPLICATION D

### INSTALLING WALL MOUNTING BRACKETS TO BRICK OR STONE:

- Place a safe ladder on a flat, dry, stable surface at both ends of where the awning will be installed
- Using a chalk-line and a string level (or a laser level) mark a horizontal line at your chosen height above the patio.
- Using a stud finder, mark the center of all the studs along the line where the awning will be installed. You may need to locate them on the inside of the house and measure from the outside openings to mark their locations. Failure to center bolts in structural rafters will cause premature failure and result in awning collapse and possible injury.
- Mark both ends of where the awning will be installed on that line.
- There should be one bracket within one feet of each end or close to the lateral arms and then distribute the rest of the bracket(s) evenly spaced across the awning torsion bar. Choose and mark the best studs to install the brackets on given those requirements.
- For stone: It may be necessary to use a grinder to flatten the area where the brackets are to be placed.
- Using the bracket as a template (the top of the bracket has a ridge on it), mark the holes. Place the bottom of the bracket on the chalk line.
- Use a 1/2" masonry bit to get through the brick or stone.
- Insert (2) 1/2"x 5-1/2" aluminum tubing into the holes (these can be purchased at your local home center as 3'-sections of 1/2" aluminum tubing. Use a hack saw to cut it into 5-1/2" sections.) Using a ratchet, install (2) 3/8"x8" lag screws (1/2" socket) and (4) 3/8" washers (one washer on the front and back of the bracket, per screw) to secure the bracket to the wall.
- Repeat the process for the remaining brackets.

IF YOU KNOW THE BRICK AND THE MORTAR OF YOUR HOME/BUILDING IS STRONG AND CAN HANDLE THE LOAD OF THE AWNING WITH OUT INSTALLING THE BRACKETS TO THE STUDS THEN YOU MAY DO THE FOLLOWING (AWNTECH DOES NOT TAKE ANY RESPONSIBILITY FOR ANY DAMANGES TO THE PROPERTY AND ANY INJURIES TO THE PEOPLE IF THE AWNING IS PULLED OFF FROM THE WALL). For brick surfaces: Use a 5/16" masonry bit to drill 3" deep holes into the surface. Insert two 5/16"x3" wedge anchors into the hole. Install a washer on each anchor. Place the bracket so the anchors come through the mounting holes. Install another washer and fully tighten the nuts.

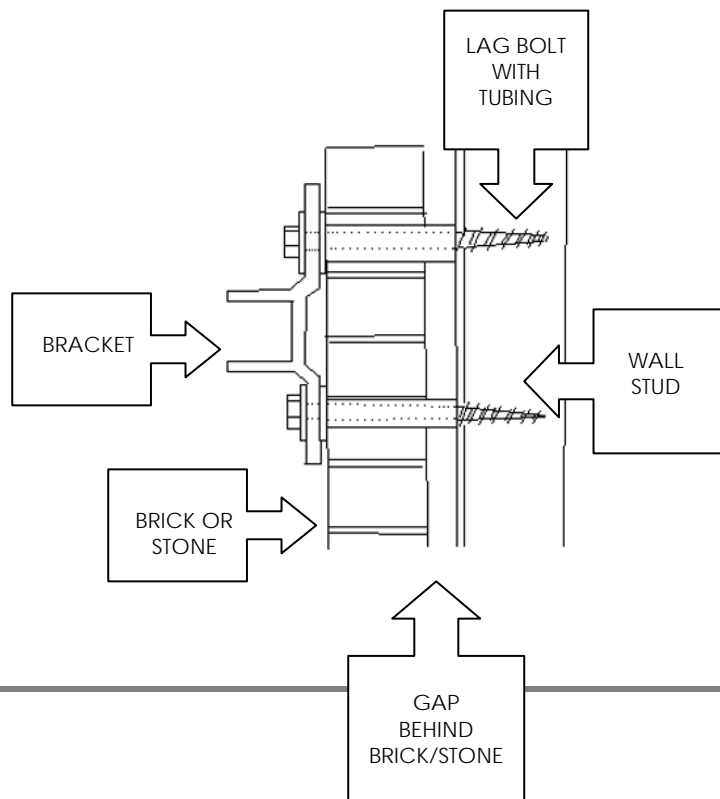

# APPLICATION E

## INSTALLING WALL MOUNTING BRACKETS TO METAL BUILDINGS:

- Place a safe ladder on a flat, dry, stable surface at both ends of where the awning will be installed
- Using a chalk-line and a string level (or a laser level) mark a horizontal parallel with the exterior wall surface at least 6" from the wall.
- Mark both ends of where the awning will be installed on that line.
- Identify the location of the structural supports. Typically surface screws make them easy to locate.
- The structural supports are typically vertical, so you will need to mount a piece of 2x6 treated lumbers (4" longer than the awning) onto the surface. The bottom corner of the lumber should be on the chalk-line. Mount it temporarily with 3" self tapping sheet metal screws. Mount another 2x6 (same length) one on the inside of the metal, again with 3" self tapping sheet metal screws.
- There should be one bracket within one feet of each end or close to the lateral arms and then distribute the rest of the bracket(s) evenly spaced across the awning torsion bar. Use the chalk-line to mark another line on the 2x6 lumber, 1" up from the bottom edge. Using the bracket as a template, mark the holes. Place the bottom of the bracket on the chalk line
- Drill holes through the front board with a 5/16" wood/metal bit.
- Using a ratchet, install (2) 5/16"x5" lag screws (9/16" socket) and (2) 5/16" washers to secure the bracket through the front board and into the back board.
- Repeat the process for the remaining brackets.
- Seal the top of the board where it meets the metal siding with clear paint-able silicone.

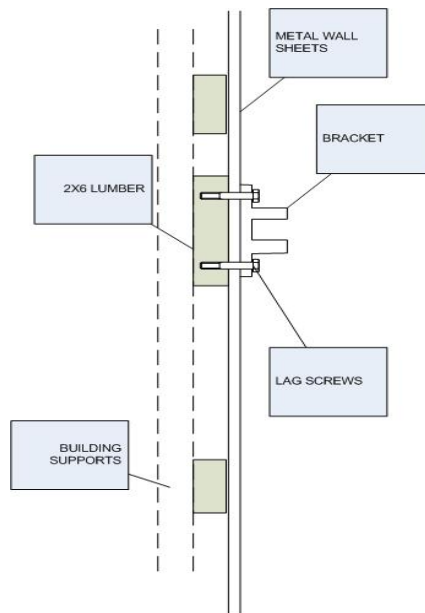

## APPLICATION F

### INSTALLING WALL MOUNTING BRACKETS TO CONCRETE BLOCK WALLS:

- Place a safe ladder on a flat, dry, stable surface at both ends of where the awning will be installed
- Using a chalk-line and a string level (or a laser level) mark a horizontal parallel with the exterior wall surface at least 6" from the wall.
- Mark both ends of where the awning will be installed on that line.
- You must have access to the back side of the block. (It cannot be a finished surface).
- Purchase one piece of 2x6 lumber the length of your awning. You will also need (2) 5/16" x 24" all-thread, (4) 5/16" washers and (2) 5/16" nuts for each bracket. You will need a drill a 12" long 5/16" masonry bit and a 5/16" wood bit.
- There should be one bracket within one feet of each end or close to the lateral arms and then distribute the rest of the bracket(s) evenly spaced across the awning torsion bar. Use the chalk-line to mark another line on the 2x6 lumber, 1" up from the bottom edge. Using the bracket as a template, mark the holes. Place the bottom of the bracket on the chalk line
- Drill holes with the masonry bit into the block in the marked locations. Drill all the way through.
- Use the holes as a template to drill holes through the 2x6 that will be mounted on the back side. Insert the all-thread, install the washers and nuts and secure them with a ratchet.
- Repeat the process for the remaining brackets.

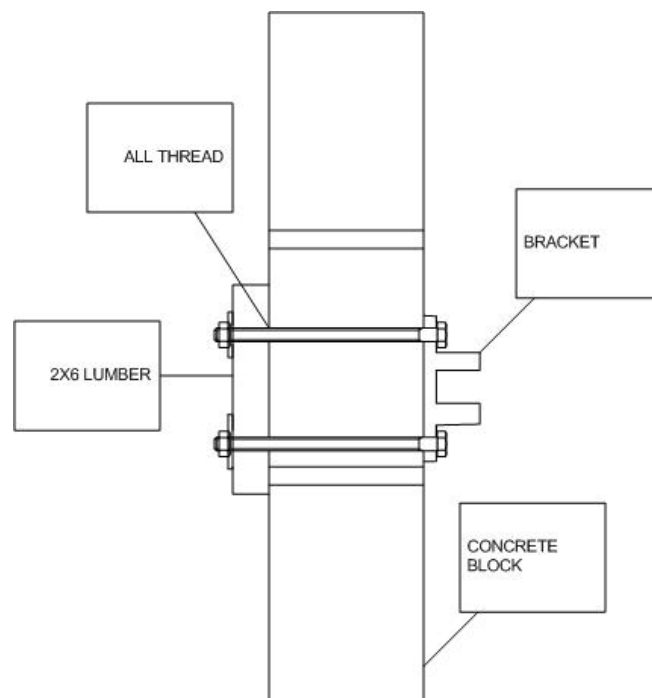

## APPLICATION G

### INSTALLING EAVE MOUNTING BRACKET TO EAVE OR BOTTOM OF A BEAM: OPTIONAL AND CAN BE PURCHASED SEPARATELY

- Place a safe ladder on a flat, dry, stable surface at both ends of where the awning will be installed
- Using a chalk-line and a string level (or a laser level) mark a horizontal parallel with the exterior wall surface at least 6" from the wall.
- Using a stud finder, mark the center of all the boards that the Eaves are secured to along the line where the awning will be installed. Failure to center bolts in structural boards will cause premature failure and result in awning collapse and possible injury.
- Mark both ends of where the awning will be installed on that line.
- There should be one bracket within one feet of each end or close to the lateral arms and then the rest of the bracket(s) evenly spaced across the awning torsion bar. Choose and mark the best studs to install the brackets on given those requirements.
- Using the bracket as a template, mark the holes. Place the front of the bracket on the chalk line
- Drill a pilot hole into the board with a 3/16" wood/metal bit.
- Using a ratchet and 9/16" socket, install (2) 5/16"x3" lag screws and (2) 5/16" washers to secure the bracket into the boards.
- Repeat the process for the remaining brackets.

#### MOUNTING EAVE BRACKET TO A BEAM

#### MOUNTING EAVE BRACKET TO SOFFIT/EAVE

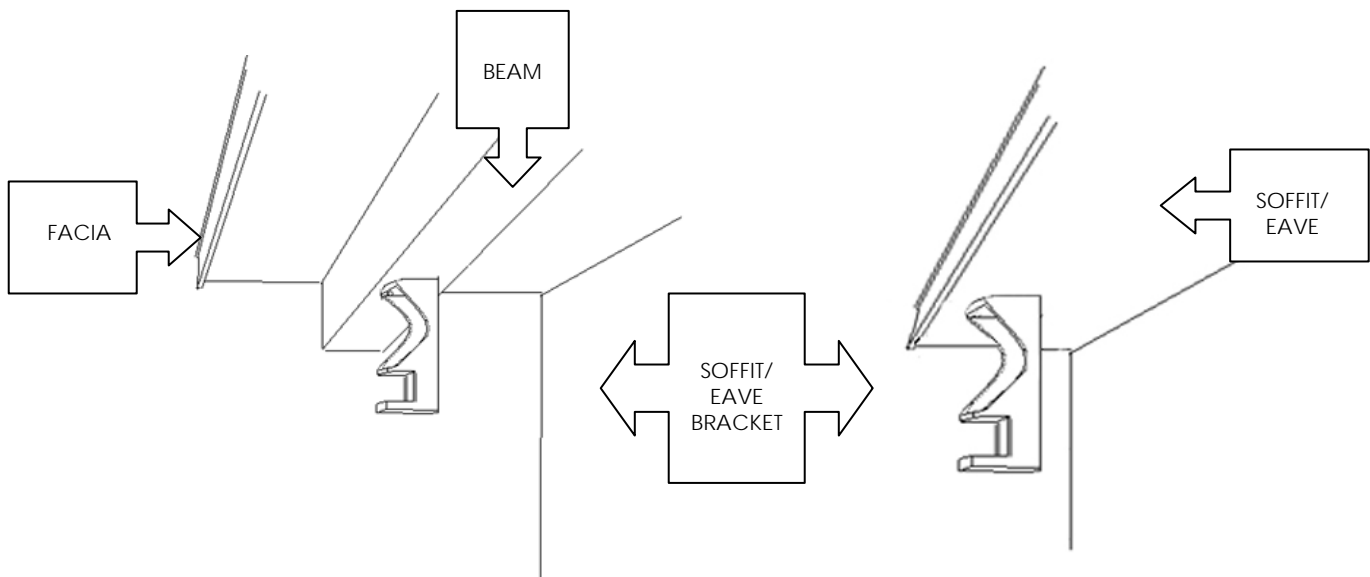

## APPLICATION H

### INSTALLING ROOF MOUNTING BRACKET TO ROOF:

OPTIONAL AND CAN BE PURCHASED SEPARATELY

**WE HIGHLY RECOMMEND THAT YOU HIRE A PROFESSIONAL ROOFING CONTRACTOR TO INSTALL THE ROOF MOUNT BRACKETS AND AWNING. IMPROPER INSTALLATION CAN CAUSE INJURY TO THE INSTALLER AND DAMAGE THE PROPERTY**

- Place a safe ladder on a flat, dry, stable surface at both ends of where the awning will be installed
- Using a stud finder, mark the center of all the rafters along the line where the awning will be installed. Failure to center bolts in structural boards will cause premature failure and result in awning collapse and possible injury.
- Mark both ends of where the awning will be installed on that line.
- There should be one bracket within one feet of each end or close to the lateral arms and then the rest of the bracket(s) evenly spaced across the awning torsion bar. Choose and mark the best rafters to install the brackets into given those requirements.
- Purchase one piece of galvanized flashing 12"W X 24"D and (3) 5/16" rubber washers per bracket. Using the bottom holes in the base bracket (A) as a template, mark and cut 5/16" holes along the centerline of the flashing, 6" from each side. Install the rubber washers between the bracket and the flashing.
- Using a stiff putty knife pry the shingles apart 24" (about 24" wide) back from the edge of the roof.
- Slip the back of the flashing at least 8" under the shingles. Center the holes and rubber washers over the selected rafters.
- Using a ratchet, install (2) 5/16"x3" lag screws (9/16" socket) and (3) 5/16" washers through bracket A, the rubber washers, shingles and decking into the rafters.
- Install wall brackets securely on the face of Bracket (B) with the nuts, washers and bolts provided.
- Insert a 5/16" x 1" hex bolt into the bottom holes of Bracket (A) and (B). Install lock washers and nuts loosely.
- Using a ratchet and 9/16" socket, install 5/16" x 1" hex bolts, lock washers and nuts to secure the support arms (C) to the inside edges of Bracket A.
- Using a level, install the support arm to bracket B through the holes that most closely set bracket B vertical.
- Tighten all nuts and bolts securely.
- Seal the shingles back together with quality roofing sealer.

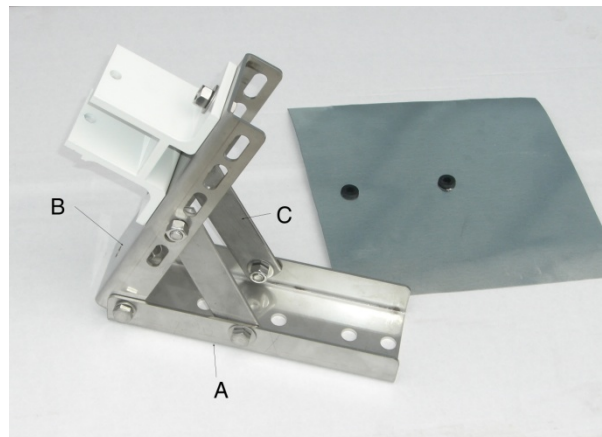
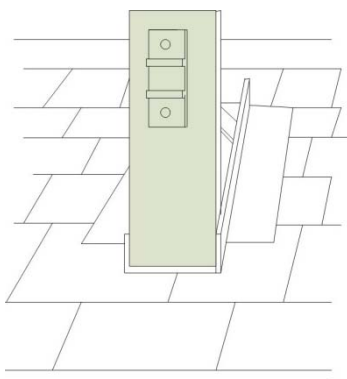

## INSTALLING THE AWNING ONTO THE BRACKETS

- Place safe ladders on a flat, dry, stable surface at both ends (and in the middle if wider than 12') of where the awning will be installed
- For the DESTIN® only: Assemble the hood and secure the mounting bracket to the back of the back bar of the awning (see diagram on page 26 for installation instructions)
- Assure that the awning is in the closed position and the arms are tied closed. This will prevent the unit from inadvertently opening while being lifted into the brackets.
- With the help of a capable assistant (or two-if your awning is more than 12' long), lift the awning to the brackets and slip the torsion bar (back bar) into the brackets. Make sure the torsion bar slides all the way to the back of the bracket. Then slide the retaining bolts into the brackets. Center the unit as needed then tighten the nuts on the retaining bolts.
- If the torsion bar does not easily slip into the brackets, make sure the torsion bar is held in place and lift or lower the front bar slightly till it is horizontal with the torsion bar. You may need to loosen the brackets slightly to accomplish this fit.
- Once fully secure, retighten the nuts on the brackets and carefully cut the zip ties off the arms.

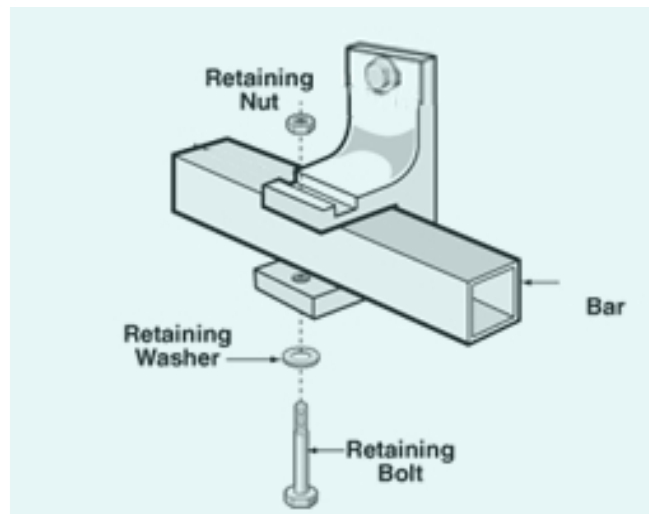

# ADJUSTING THE PITCH OF THE AWNING

**CAUTION: DO NOT ATTEMPT TO ADJUST THE PITCH IN THE RETRACTED POSITION IF YOU ORDERED AN ADJUSTABLE PITCH CRANK.. DO NOT STOP..GO DIRECTLY TO NEXT STEP**

- Extend the awning completely.
- First identify the pitch adjustment brackets (K). (see diagram below)
- Loosen the top bolt (P) and bottom bolt (R) (do not remove them, just allow them to be moved) on the bracket at both ends. This operation requires a 6mm and 8mm Allen wrench.
- Have your helper(s) hold the front end of the awning.
- Turn Allen bolt (Q) counter-clock-wise to lower the pitch and clock-wise to raise the pitch on both ends.
- Once you adjust the pitch to your desired level, tighten up the top bolt (P) and bottom bolt (R).
- If the front bar is lower on one side, simply loosen (P) on the opposite side bracket and make the appropriate adjustment to (Q). After you are happy with the results retighten (P).
- The pitch adjustment range is 0 degrees to 60 degrees. In order to get “no drop” at the full extension of the awning you need to insert the “R” bolt in the first of the five holes. Example in the photo shows the bolt is in the second hole.

## K – PITCH ADJUSTMENT BRACKET

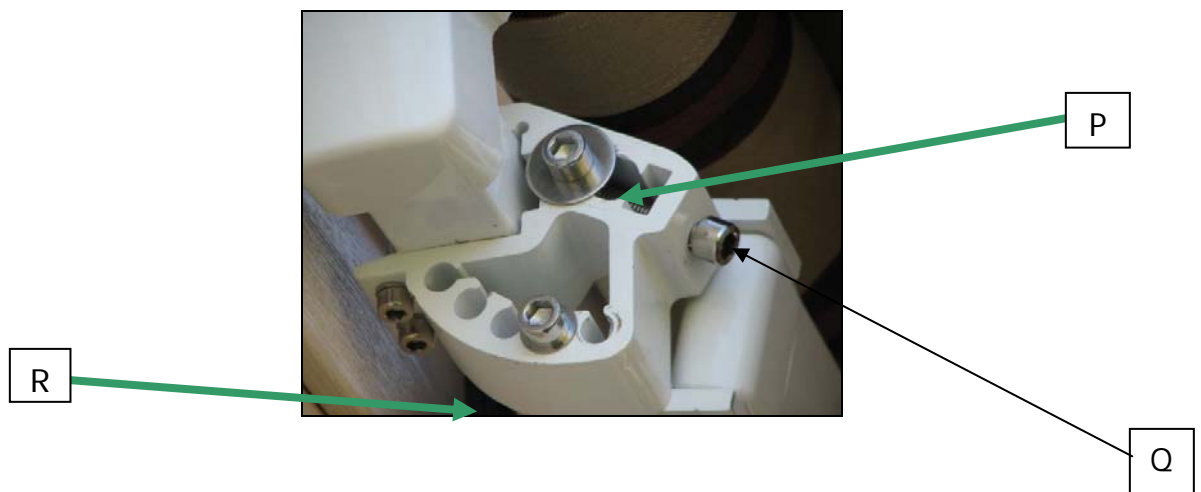

# INSTALLING A NEW MOTOR ON A MANUAL AWNING OR TO REPLACE THE MOTOR

You must have a 110V outdoor electrical outlet on the wall to the either left or right side of the awning for a successful installation. Ideally it would be at 6' above the surface of the patio but standard height will work just fine.

## **STOP!**

**YOU MUST REMOVE THE AWNING FROM THE MOUNTING BRACKET AND LAY IT SAFELY ON THE GROUND. THIS MUST BE DONE IN THE RETRACTED POSITION. THE ARMS SHOULD BE TIED CLOSED BEFORE REMOVING IT FROM THE BRACKETS.**

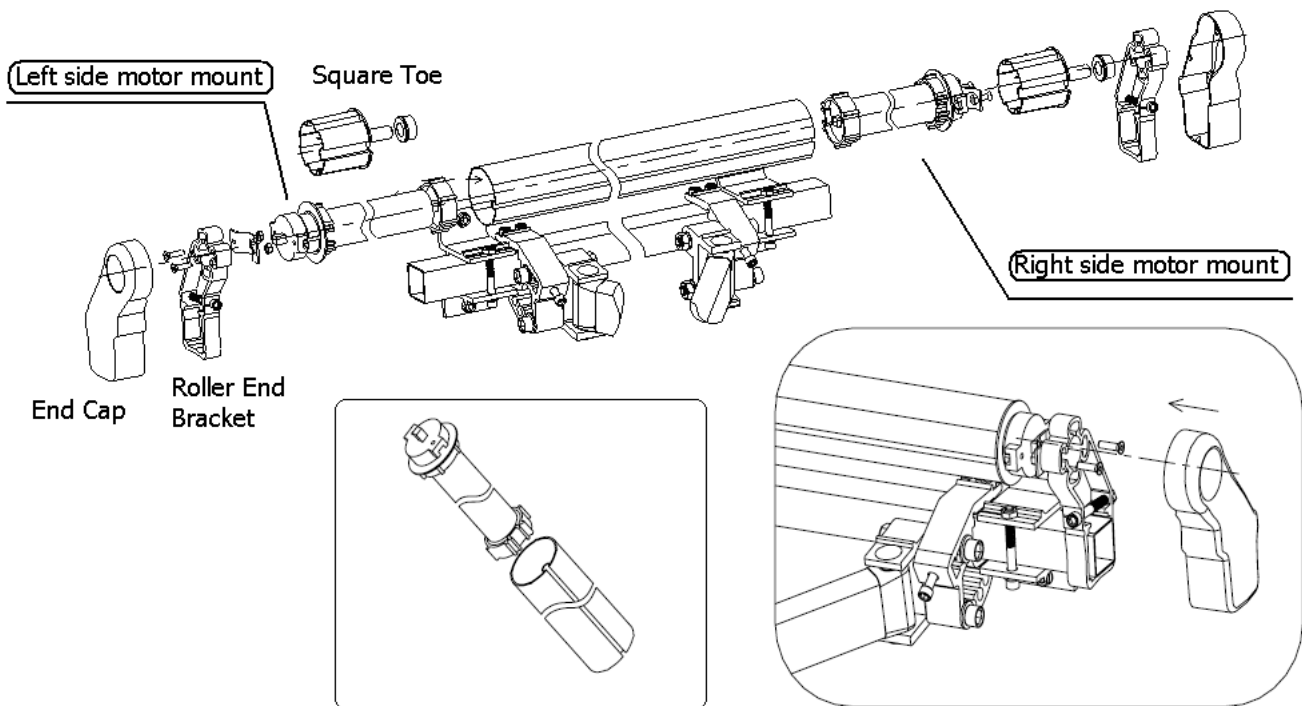

# **STEPS FOR INSTALLING A NEW MOTOR (AT45MR)**

## **ON A MANUAL AWNING OR TO REPLACE AN EXISTING MOTOR**

### **THIS MODEL HAS AN INTERNAL RECEIVER**

1. After your awning is safely on the ground, remove the end cap
2. **BE SURE THAT THE ARMS ARE TIED SECURELY (VERY IMPORTANT)**
3. Un-tighten the roller end bracket securing bolts and remove the bracket from the torsion bar by sliding it to the left end of the bar
4. Remove the gear as you no longer needed to operate the motorized awning
5. Remove the square toe as you no longer need it (motor will replace square toe)
6. Install the motor by sliding it all the way into the end of the roller tube
7. Attach the hardware as it is shown in the diagram
8. Re-install the roller end bracket by sliding the bracket onto the end of the torsion bar. Tighten the nuts on the securing bolts of the roller end bracket and put the cotter pin in the shaft hole to hold it in place.
9. Install the left end cap
10. Install the wand eye on the bottom of the shaft on the motor with the spring clip provided. **DO NOT INSTALL OR USE A WAND UNLESS THE MOTOR IS TURNED OFF.**
11. Safely re-install and secure the awning to the mounting brackets
12. Carefully remove the ties from the arms
13. Plug in the motor
14. Install the wireless control bracket in a covered area nearby. It should already be set to the same frequency of the motor. Press the lower button to project the awning. Press the middle button to stop. Press the upper button to retract the awning.
15. If the awning does not extend fully or extends too much or does not retract all the way or continues to retract more after it is completely retracted then you may have to follow the instructions for the limit control settings in order to set the limits to open and close the awning. Refer to the instructions for the limit control adjustments in page number 25-26. If the limits are not set correctly then there will be a high chances of damaging the awning or motor.



# MODEL – DC34 for AT45MR Remote Control

The Awntech Tubular Motor operates at a maximum distance of 150 feet.

## Technical Specifications:

- Power Supply - 12V battery
- Protecting Index - IP30
- Working Temp. - 23 degrees F to 160 degrees F

The Maui<sup>®</sup> motorized awning is programmed to extend and retract fully. This motor has manual over-ride option available. In case of power failure you can retract or extend the awning by using the rocker handle.

## Battery Life:

**Expected life of the battery (3W) is 3 years with operating load of 3 to 4 times a day. If the battery is low, the LED on the front of the remote control will not light up or send signal to the receiver. To change the battery, open the back panel of the remote control and replace the battery.**

## Trouble Shooting:

1. If the LED light on the remote control is off:
  - Please check the battery
2. If the LED light is red on the remote control and the motor doesn't function:
  - Please check the power supplies to both the receiver and the motor
  - Check cable connections
  - The motor has an internal temperature control and shuts off the motor for twenty minutes until the motor cools off. So...wait for twenty minutes and then try to operate it.

**In case of an emergency or if you have questions, contact our technical support team at 800-203-7049 M-F (9-5 CST).**

## Programming:

**The programming button (P) is located in the battery compartment. Please open the battery compartment and locate a small rectangular shaped push button.**

1. To program or reset the transmitter (Remote Control)  
Power up the motor and then within 12 seconds push the **“programming button”** three times
2. To Delete the programming of an old transmitter (Remote Control)  
Do the following: Power up the motor, press the **“programming button”** once, within 4 seconds press the **“stop”** button, then within 4 seconds press the **“programming button”** once
3. To change the direction  
Do the following: Power up the motor, press the **“programming button”** once, within 4 seconds press the **“down”** once, then within 4 seconds press the **“programming button”** once
4. Appending a transmitter (Remote Control)  
Do the following: Power up the motor, press the **“programming button”** twice of the existing remote, within 4 seconds press the **“programming button”** of the appending remote (remote)
5. Dot control function: Power up the motor, press the **“programming button”** once, within 4 seconds press the **“up”** button once, within 4 seconds press **“programming button”** once

## HOW TO ADJUST LIMIT CONTROLS ON YOUR MOTOR

**CAUTION: IMPROPER ADJUSTMENTS CAN CAUSE THE AWNING MOTOR TO BREAK.**

**MOTOR Model: AT45MR**

**Limit Adjustment Control Operation**

**VERY IMPORTANT:  
YOU MUST ADJUST THE CONTROLS FROM THE BOTTOM OF THE MOTOR**

**The motor has internal temperature cutoff switch. If the motor gets too hot it will stop working, it will start working after 20 minutes or as soon as motor cools down. Do not worry, this motor has manual override option and you can always open or close the awning manually by using the crank handle.**

This motor has a limit control switch to control the extension and retraction of your unit. The limit adjustments controls are in **Red and White** are located next to the electrical cord of the motor. In order to adjust the limit controls you would need to insert the tool looks like wand to turn the controls either "clock wise" or "counter clock wise"

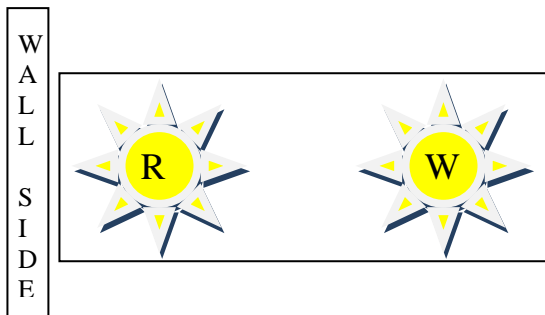

LIMIT CONTROLS (WHEN YOU LOOK UP)

**LEFT MOTOR MOUNT (when you face the house):**

If the awning stops from closing completely:

1. Identify the **Red Limit Control** (Close to the wall)
2. If the awning stops from retracting completely, then turn the control "COUNTER CLOCK WISE" direction (one turn at a time) until it retracts completely.

If the motor continues to turn even after the awning completely retracted then do the following:

1. Identify the **Red Limit Control** (Close to the wall)
2. Stop by pressing the stop button
3. Extend the awning about two feet and then
4. Then turn the control "CLOCK WISE" (three full turns) and then push the button to retract. If the awning still continues to retract more then repeat the steps until it is completely adjusted.

If the awning doesn't extend fully or to your desired extension then do the following:

1. Identify the **White Limit Control** (Away from the wall)

2. If the awning doesn't extend fully or to your desired extension, then turn the Limit Control "COUNTER CLOCK WISE" until it opens completely or it reaches till your desired extension

If the awning continues to extend beyond your desired extension, then do the following:

1. Stop by pressing "Stop" button
2. Retract the awning by pressing "Retract" button for about two to three complete turns and press "Stop" to stop it from further retracting
3. Turn the **White Limit Control** "CLOCK WISE"
4. Press to extend, if it extends still too much then
5. **Repeat** the above steps until it reaches your desired extension.

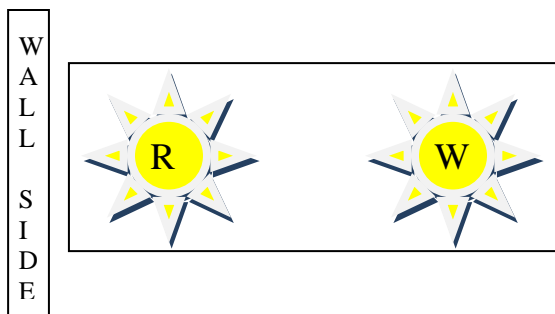

LIMIT CONTROLS (WHEN YOU LOOK UP)

### **RIGHT MOTOR MOUNT (when you face the house):**

If the awning stops from closing completely:

1. Identify the **White Limit Control** (Away from the wall)
2. If the awning stops from retracting completely, then turn the Limit Control "CLOCK WISE" direction (one turn at a time) until it retracts completely.

If the motor continues to turn even after the awning completely retracted then do the following:

1. Identify the **White Limit Control** (Away from the wall)
2. Stop by pressing the stop button
3. Extend the awning about two feet and then
4. Then turn the control "COUNTER CLOCK WISE" (three full turns) and then push the button to retract. If the awning still continues to retract more then repeat the steps until it is completely adjusted.

If the awning doesn't extend fully or to your desired extension then do the following:

1. Identify the **Red Limit Control** (Close to the wall)
2. If the awning doesn't extend fully or to your desired extension, then turn the Red Limit Control "CLOCK WISE" until it opens completely or it reaches till your desired extension

If the awning continues to extend beyond your desired extension, then do the following:

1. Stop by pressing "Stop" button
2. Retract the awning by pressing "Retract" button for about two to three complete turns and press "Stop" to stop it from further retracting
3. Turn the **Red Limit Control** "COUNTER CLOCK WISE"
4. Press to extend, if it extends still too much then
5. **Repeat** the above steps until it reaches your desired extension.

You can always use extend and retract manually by pressing the controls on your remote control.

## **INSTALLING THE HOOD (SEE THE REVISED)**

# HOOD ASSEMBLY INSTRUCTIONS FOR DESTIN MODEL RETRACTABLE AWNING

Parts List		
Name	Awning Size	Qty
Hood	All	1
S-Brackets	8	1
S-Brackets	10, 12	2
S-Brackets	16, 18, 20	3
S-Brackets	24	6
End Caps	All	2
Hardware		as needed



# INSTALLING AN ADJUSTABLE PITCH CRANK

(OPTIONAL AND CAN BE PURCHASED SEPERATELY)

## STOP!

YOU MUST REMOVE THE AWNING FROM THE MOUNTING BRACKET AND LAY IT SAFELY ON THE GROUND. THIS MUST BE DONE IN THE RETRACTED POSITION. THE ARMS SHOULD BE TIED CLOSED BEFORE REMOVING IT FROM THE BRACKETS.

1. After your awning is safely on the ground, remove the nuts and bolts holding the manual pitch brackets to the arms and torsion bar.
2. Loosen the front arm bolts slightly (enough for them to move on the bar).
3. Remove the manual pitch brackets by sliding them off of the torsion bar.
4. Install the adjustable pitch cranks in their place by sliding them onto the torsion bar (you will receive 1 crank per arm when you place an order). The adjustable pitch crank and the front arm brackets will be in a different location from where the brackets were originally.
5. Install and tighten all bolts to the arm, torsion bar and front bar.
6. Safely re-install and secure the awning to the mounting brackets
7. Carefully remove the ties from the arms.
8. Your wand is interchangeable, move it from the crank arm to the pitch crank arm as desired.



# INSTALLING THE BREEZE SUPPORT LEGS

(OPTIONAL AND CAN BE PURCHASED SEPERATELY)

**BREEZE SUPPORTS ARE NOT DESIGNED TO MAKE RETRACTABLE AWNINGS A PERMANENT STRUCTURE.**

- On the bottom track of the front bar there is a nut and washer next to each arm bracket.
- Remove the nuts and washers, insert the bolts into the holes in the L-shaped bracket on each leg support. Re-install the washers and nuts. Tighten the nuts.
- If your patio is concrete: using a 3/8" shank-1/2" masonry bit, drill (2) 1-1/2" holes into your patio at the spot that the legs are plumb when the awning is fully projected (You will need a level for this). Insert (2) 1/4" machine screw anchors into the hole, place the bottom bracket over it and screw the thumb screw down until the anchor does not move. Once secure you can remove the thumb screw at will without loosening the anchor.
- If your patio is wood: Using a 5/16" wood bit, drill (2) 2" holes into your patio at the spot that the legs are plumb when the awning is fully projected. Install (2) 1/4" tee-nuts into the hole and hammer them flush with the surface. Install (2) 1/4"x1" thumb screws through a 1/4" washer, the leg bracket and into the tee-nut.
- Adjust the height control nut on the legs to the desired length, and tighten.
- In the case of rain, snow, sleet or high winds, un-screw the thumb screws at the base of the legs and retract the awning. You should always retract your awning when not in use.



Breeze support legs



Machine screw anchor

Tee-nut

Thumb screw

# INSTRUCTIONS FOR REPLACING CENTER SUPPORT BRACKETS

20', 22' & 24' MAUI® & DESTIN® MODELS

- Remove nuts and bolts that hold the bracket to the roller.
- Place the new roller bracket between the brackets and install the nuts and bolts securely.



## REPLACING AWNING FABRIC

- If you have a motor, turn it off.
- Manually crank the awning out to full projection
- Remove the front bar end caps
- Using the provided Allen wrench, unloosen the bullets at each end of the front bar C channel.
- Ask your helper to get on a step ladder about five feet from the wall on the non-motor/non-crank side of the awning.
- On a ladder mildly push the front bar toward the wall. This will loosen the fabric
- Remove the fabric by pulling it straight out the C-channel on the non-crank/motor side of the awning. You should pull out the front and back simultaneously.
- Install the new fabric by sliding the ends back into the C-channel from the same side. You may need to push the front bar slightly toward the wall while two helpers feed the beads into the C-channel. There is a slot in the end of the roller eye for it to slide into.
- Reinstall both bullets and tighten the Allen screws.
- Re-install the front end caps
- Retract the awning manually.
- Turn on the motor.

## REPLACING THE VALANCE

- Remove the right and left front end caps (I)
- Using the provided Allen wrench, unloosen all the bullets at the ends of the fabric.
- Remove the bullets from the C-channel.
- Remove the valance by pulling on it from the right side.
- Reinstall the new valance by sliding the top bead into the same slots in the front bar (J)
- Reinstall both bullets and tighten the Allen screws.
- Reinstall the right and left front end caps (I)

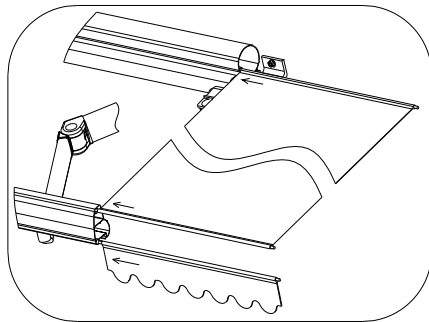

## REPLACING PROJECTION ARMS

**STOP! CAUTION: DO NOT TRY TO REPAIR THE ARMS WITHOUT READING AND FOLLOWING THESE INSTRUCTIONS FIRST. FAILURE TO DO SO MAY CAUSE INJURY AND DAMAGE TO YOU, YOUR PROPERTY AND THE AWNING.**

Please observe the **CAUTION: HIGH TENSION PROJECTION ARMS LABELS** when replacing the lateral arms of your awning. **These arms are loaded with high tension springs and can cause severe personal injury and property damage if extreme caution is not used. Follow the step-by-step instructions to change the arms of your Retractable Awning:**

1. Close or retract the awning completely.
2. Tie each of the arms closed (in folded/retracted position). They should not be tied to either the front or back bar.
3. Once ALL arms are securely tied, you are ready to remove one arm. The arms are marked "left" or "right". Determine left or right by facing the wall where the awning is mounted. (Left is on the left in front of you, right is on the right)
4. First, remove the nuts and bolts that secure the arm to the front bar.
5. Then, remove the nuts and bolts that secure the arm to the back bar.
6. Remove the bar from the awning.
7. Tie the replacement arm closed with zip ties.
8. Install the replacement arm by attaching it at the back bar first and the front bar last. Do not tighten the nuts on the bolts, they require adjustment.
9. After you have replaced the arm, lift the hinge side of the arm as high as it will go (this aligns the arms), then tighten up all the nuts on the bolts (at front and back bars) connecting the arms to the awning frame.
10. If you have more than one arm to replace, repeat steps 4-9 for each arm.
11. It is very important that all bolts are fully tightened before removing the ties. Be careful not to damage the awning when removing the ties. If you have questions, please contact Technical Support at 800-203-7049.

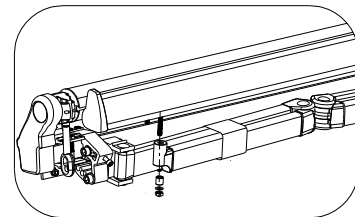
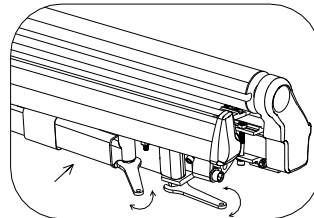
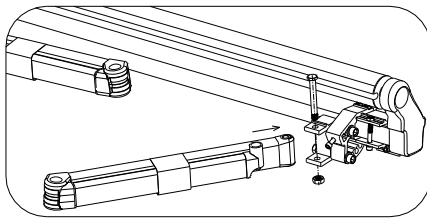

**ALWAYS KEEP YOUR AWNING RETRACTED WHEN NOT IN USE. ALWAYS RETRACT YOUR AWNING DURING RAIN, ICE, SLEET, SNOW, HIGH WIND AND GUSTY CONDITIONS. FAILURE TO DO SO CAN DAMAGE YOUR AWNING. ANY DAMAGE RESULTING FROM FAILURE HEED THIS WARNING WILL NOT BE COVERED UNDER YOUR AWNTECH CONDITIONAL WARRANTY.**

### WARRANTY

## 5-Year Limited Manufacturer's Warranty

### A. WHO GIVES THIS WARRANTY? Awntech Corporation

**B. WHO IS ENTITLED TO THIS WARRANTY?** This Warranty applies only to the original purchaser who paid for the product and may not be assigned or transferred to subsequent owners. This Warranty applies only to products purchased and installed in the US.

**C. WHAT ARE THE RESPONSIBILITIES OF AWNTECH CORPORATION UNDER THIS WARRANTY?** Subject to the terms and conditions set forth herein, Awntech Corporation will furnish replacements for parts found by Awntech Corporation to be defective in design, manufacture or assembly, under each specific component or product warranty as set forth below.

### D. WHAT ARE THE RESPONSIBILITIES OF THE ORIGINAL PURCHASER UNDER THE WARRANTY?

1. Before any claims may be made under this Warranty, the original purchaser must have paid in full for the product covered under the Warranty, according to the terms and conditions of the pay-plan defined in the original order. IF THE PURCHASER HAS FAILED TO MAKE FULL PAYMENT, THIS WARRANTY SHALL BE NULLIFIED AND AWNTECH CORPORATION SHALL BE RELIEVED FROM ANY RESPONSIBILITY OR LIABILITY UNDER THIS WARRANTY. The purchaser agrees and acknowledges that this Warranty agreement constitutes an executor contract.
2. The purchaser must use care in installation, maintenance, operation, use, and storage of the product in accordance with the instructions contained in the owner's manual. ANY FAILURE TO INSTALL, MAINTAIN, OPERATE, USE AND STORE THE PRODUCT IN ACCORDANCE WITH THE INSTRUCTIONS CONTAINED IN THE OWNER'S MANUAL WILL NULLIFY THIS WARRANTY AND RELIEVE AWNTECH CORPORATION FROM ANY RESPONSIBILITY OR LIABILITY UNDER THIS WARRANTY.
3. Promptly notify Awntech Corporation of any claims.
4. The purchaser may be required to provide a photograph of any defective parts. The purchaser may also be required to pay a deposit until the defective parts are returned to Awntech Corporation for inspection. The purchaser must obtain a return authorization form from Awntech Corporation's customer service department prior to the return of any merchandise and after having received such authorization, return the part or product, freight prepaid, to Awntech Corporation.

### E. WHAT IS COVERED UNDER THIS WARRANTY?

**1. The following components of Awntech Beauty-Mark® models and their accessories (defined as accessories attached to the awning) are covered under this Warranty, subject to the limitations set forth below. These components have a five (5) year limited (prorated) warranty, against manufacturer's defects as outlined below:**

**(a) Should the purchaser promptly notify Awntech Corporation of such defects within one year (12 months) from the date of the original purchase, the defective component will be replaced at no charge. Awntech reserves the right to ask for the defective part to be returned and/or photos of the defective part.**

**(b) After one year but within five years (60 months) from the date of the original purchase, a defective component will be replaced upon the purchaser's payment of 1/60<sup>th</sup> of the full retail cost of the component for each month of use prior to the claim.**

### COVERED COMPONENTS: for Retractable Awnings

**ELECTRICAL AND ELECTRONIC COMPONENTS** limited manufacturer's warranty for one year from the purchase date and for manufacturing defects only

**STRUCTURAL SUPPORTS**, all supporting components (excluding **Lateral Arms** and their fittings) are warranted not to fail for five (5) years provided that the components are not subjected to excessive winds or water pooling on the fabric.

**FRONT ROLLER BAR** is warranted against any and all damage including cracking and permanent bowing that would affect the performance of the awning provided that the awning is not subjected to excessive winds or water pooling on the fabric.

**ACRYLIC and POLYESTER FABRIC** is warranted for five (5) years against:

(a) Excessive fading under normal conditions if maintained, operated, used, and stored in accordance with the instructions contained in the owner's manual.

(b) Mildew on acrylic fabric. Mildew will not form on the fabric itself, but may form on dirt and dust that have not been removed from it. Please see maintenance instructions for proper cleaning—outlined in owner's manual.

(c) Excessive cracking or peeling under normal conditions if maintained, operated, used, and stored in accordance with the instructions contained in the owner's manual, and provided that the awning is not subjected to excessive winds or water pooling on the fabric.

**DRIVE UNIT** is warranted for five (5) years not to fail under normal conditions if maintained, operated, used, and stored in accordance with the instructions contained in the owner's manual.

**AWNING ACCESSORIES** (defined as accessories attached to the awning) are warranted for five (5) years not to fail under normal conditions if maintained, operated, used, and stored in accordance with the instructions contained in the owner's manual.

# RETURNS, DAMAGES

**RETURN QUALIFICATION:** You can only return a product if it is defective upon arrival. If you simply do not like it for any other reason, you will be given merchandise credit only.

**DAMAGED MATERIAL:** Damage occasionally occurs during shipping. Scrapes, dents, and rips in the outer packaging that could indicate possible damage should be described to the carrier at the time of delivery. If damage to the product seems apparent, the shipment should be refused.

**FABRIC DYE-LOT AND LIGHTING VARIATION:** Fabric dyes may vary slightly from run to run. This is a normal and unavoidable. Different lighting types and lighting direction may cause the fabric you chose on the website to appear slightly different than the actual fabric does in full sunlight.

**TRIPLE CHECK YOUR MEASUREMENTS:** To avoid disappointment and frustration, please triple check all measurements to assure that your awning will fit properly in the location you intend. Please make sure that you have at least 1'-2' extra wide area available to install the awning and also make sure that you have enough open space for the projection.

**HAZARDOUS MATERIAL QUALIFICATIONS:** None

**RETURNS/ORDER EXCEPTION CONTACT:**

Customer Service: Phone 817-354-9600, Fax 817-354-9612, email [customers@awntech.com](mailto:customers@awntech.com)

**TO ACQUIRE A RETURN OR REPAIR AUTHORIZATION NUMBER  
YOU MUST GO THROUGH OUR WARRANTY PROCESS BELOW**

1. Email or mail a photo of the damaged parts to:  
EMAIL: [customers@awntech.com](mailto:customers@awntech.com)  
MAIL: Customer Support, Awntech Corporation, 3600 Bell Dr., Bdg. B-E, Hurst, TX 76053

**Authorized returns should be shipped to:**

Returns  
Awntech Corporation  
3600 Bell Dr., Buildings B-E  
Hurst, TX 76053

FOR CLEANING, CARE & MAINTENANCE INSTRUCTIONS GO TO [WWW.AWNTECH.COM/CLEANING](http://WWW.AWNTECH.COM/CLEANING)

FOR TECHNICAL SPECIFICATIONS GO TO [WWW.AWNTECH.COM/TECHNICAL](http://WWW.AWNTECH.COM/TECHNICAL)

FOR ORDERING OPTIONAL ACCESSORIES OR REPLACEMENT PARTS GO TO  
[WWW.AWNTECH.COM/PRODUCTS](http://WWW.AWNTECH.COM/PRODUCTS)

FOR ANSWERS TO FREQUENTLY ASKED QUESTIONS GO TO [WWW.AWNTECH.COM/FAQ](http://WWW.AWNTECH.COM/FAQ)

FOR A COPY OF THIS MANUAL GO TO [WWW.AWNTECH.COM/MANUALS](http://WWW.AWNTECH.COM/MANUALS)

TO SPEAK TO AN AWNTECH REPRESENTATIVE CALL

**800-200-5997 or 800-203-7049**

# DETERMINING AWNING SIZE AND PLACING AN ORDER

## Determine the width of your awning

- Keep in mind that the wider the area the more space to arrange and entertain you will have and the more shade you will receive.
- Measure the flat space where you wish to place the awning. That space must be at least 8'-0" off the surface of the patio and is typically lower than 10'-0".
- Every horizontal space on a wall must be at least 9.5" tall for the Maui model and 10.5" for the Destin model.
- Every horizontal space on a fascia must be at least 5" high.
- Every horizontal space under an eave must be at least 5" deep (if this is your choice you will need to purchase different brackets).
- The space of your choice must not cross a window, shutter, door or any other obstacle.

## Options for Upgrading Your Awning

- Motor and Wireless Control
- Wind Sensor
- Wind and Sun Sensor
- Adjustable Pitch Crank System
- Hood
- Breeze Support Legs

## Placing your order

### 1. How do I place an order?

Visit the following retailers or navigate online. They all have sites that are easy to navigate and make purchases:

**Home Depot, Lowes, Sam's Club, BJ's, Sears, K-Mart, Wal-Mart and Awntech.com**

### 2. How long does it take to receive your Beauty-mark® retractable awning?

During peak season (March-September) your awning will take 3 weeks to ship and then 4 business days to receive after that. During off-season months (October-February), we ship in 2 weeks and your awning is received 4 business days after that. Make sure you provide a cell number when placing your order. Your awning will be delivered by an LTL carrier and they will call ahead to make an appointment for delivery

# Frequently Asked Questions

**1: What is the difference between Maui Manual and Maui Motorized Retractable Awnings?** The Maui® Manual Awning is manually operated. They open easily in less than a minute using a hand-cranked gear mechanism — no electricity required. One person can operate it with ease.

The Maui® Motorized Retractable Awning has a manual override motor and an inside remote control that opens and closes the awning with the touch of a button. You plug it into a grounded electrical outlet. The motor is hidden in the roller bar.

**2: Which of the Beauty- Mark® retractable awning models is right for me?** The width of your patio area dictates the size of the awning. A motorized awning provides the convenience of easy operation with a touch of a button. A manually operated (crank) is easy to use and is less expensive than a motorized model. If you choose a motorized awning, you will need to determine where your outlet is before ordering. You may purchase your awning with the motor on either the left or right side. Left or right side is determined by knowing which side you want your cord/plug to be on (left or right if facing the awning from the front).

**3: How easy is it to install the awning?** You don't have to be a handyman or a person with a lot of experience using tools. You will need to have an electric drill and the proper drill bits for your particular wall surface and hardware. There are 2 steps involved: 1. Install the brackets; 2. Slide awning into brackets and secure. This job will require 1 person to install the brackets and 2 people to lift the awning into the brackets and secure them. Your awning comes with a step-by-step instruction manual. If you need further assistance, you can reach Awntech Customer Service Department from 8:00am to 5:00pm CST by calling 800-203-7049. An installation expert will be able to guide you through the installation process if you have questions.

**4: Can I install a retractable awning on a house with low eaves?** Yes, you can install all Beauty-Mark® retractable awnings on homes with available mounting height (ground to eaves) as low as 7 ft. under eaves, overhangs and gutters. You will need 10 inches of horizontal area above your patio door. The ideal installation height, however, is 9-10 ft. from the ground/floor.

**5: Can this awning be installed on a mobile home or a garage?** Yes, however we do not provide anchors for all types of wall surfaces. We provide anchors for brick, concrete and stone. Anchors for other surfaces may be purchased at your nearest hardware store. Please make sure you mention the wall surface and weight of the unit to the hardware representative before purchasing your anchors. If you are installing an awning on a home with siding, a treated timber beam makes a nice level surface for the installation.

**6: Why do Beauty-Mark® awnings cost so much less than other suppliers?** We sell a large number of awnings with low profit margins. Our objective is to provide the highest quality awnings for the lowest possible price so that more people can afford them. Please do not conclude that we compromise quality. Our awnings have a structural steel torsion bar (main structural bar) and stainless steel twin arm cables. Our fabrics have been tested to have a 10 year life.

**7: What type of fabric do you use and how long does it last?** Beauty-Mark® fabrics for retractable awnings have a weight of 280 grams/meter and are woven with 100% solution dyed polyester threads and treated with UV, polyurethane and mildew resistant coatings. What this means to you is that your awning is resistant to fading (UVA, UVB rays), moisture, mildew and soil. Our awnings come with a 5 year warranty for manufacturing defects how ever the electrical and electronics will only have 1 year warranty. The warranty will not cover for any labor cost.

**8: Can I leave my awning open all the time?** Retractable awnings are not built for rough weather conditions. We recommend that you retract your awning when you are not using it or purchase our Breeze® wind supports and electronic wind or wind/sun sensor. On average, retractable awnings will withstand up to 30mph wind speeds.

**9: Can I adjust the pitch of the awning?** Yes, you may adjust the pitch of the awning's front bar by as much as 20 degrees. All models have an adjustable pitch mechanism on each side of the awning. Some models need to be adjusted in the installation process. Other models have an adjustable pitch gear and crank. If your model did not come with the gear/crank mechanism you may order this accessory by calling 800-203-7049. Please see Assembly and Installation Instructions for pitch adjustment details.

**10: Will my awning leak water in the rain?** No, Beauty-Mark® Retractable Awnings will not leak water in the rain because Beauty-Mark® Fabrics are sealed with polyurethane coatings in the manufacturing process and seams are sealed before they leave the factory. The Retractable Awnings are not designed to leave them extended during the rain, high wind, snow or ice.

**11: Can I install the awning on vinyl or aluminum siding, stucco, or on masonry?** Yes. The easiest way is to mount a 1" x 5"- 6" treated/painted timber beam (the same length as your awning width) through the siding into the studs. Then you mount the awning to the studs through the timber beam. Or mount a 2" x 5"- 6" treated/painted timber beam (the same length as your awning width) through the siding into the studs. Then you mount the awning timber beam you will need to paint the beam the same color as your house or trim so it will blend in nicely with your siding or trim.

**12: Do I have to take down my awning and store it over the winter?** No. Just close the awning and leave it up all year long. Our fabric has been designed to withstand the elements year round. You may also purchase additional accessories such as a hood (stops birds from nesting on your awning), weather cover (for winter storage), wind support legs and screen room for your awning by calling 800-203-7049 or visiting us online at [www.awntech.com](http://www.awntech.com).

**13: Is the awning fabric easy to clean?** Yes. Just follow the guidelines listed in our cleaning chart above if you want to clean the awning cover while it is attached to the awning frame. Awning covers can also be removed and cleaned. Please call us at 800-203-7049 for step by step instructions on this process.

**14: Will this awning help keep the inside of my home cooler?** Yes it will keep your deck or patio up to 20 degrees cooler and block harmful UV rays that fade furniture and discolor carpets and flooring. By placing an awning on the western side of your home, you may save up to 30% on air conditioning bills during the summer months. By keeping the awning retracted during winter months, you allow the sun to warm your home and save on heating costs.

**15: What is the frame and cover made of?**

**FRAME:** Powder coated structural steel & anodized structural aluminum frame.

**PARTS, CONNECTORS & HARDWARE:** Structural weather resistant, UV treated nylon & aluminum connectors. Structural anodized aluminum and powder coated steel parts. Stainless steel hardware.

**COVER MATERIALS:** 5-Year Warranty. Fabric weight, 300 grams/sq. meter, 600 Denier X 600 Denier, 100% Solution Dyed Acrylic or Polyester. Full dye sublimation (both sides of fabric) with UV and polyurethane coatings. Life expectancy is 5 years.

**16: What tools, materials and hardware are required to install your awning?:** There are many different places to install your awning on a house. There are also many different surfaces you may need to install it on. Each of these situations is detailed on Installation Sheets located on the Owners Manual. Please refer to the sheet that best fits your situation for a full list.

**17: How many installers are needed?** 8-10 ft. (2 installers), 12-24 ft. (3 installers)

**18: What is the life expectancy of my awning?**

**LIFE EXPECTANCY:** Your Awntech retractable awning has a 5-year limited warranty but with proper care and maintenance it can last longer.

## **RISKS, WARNINGS, WARRANTY**

Please handle with care when you open the package and during assembly and installation. The frame parts are made of metal and some parts may have sharp corners. Please keep children away during assembly and installation of awnings. Warn children about the risks of damage to the awning in rough weather conditions and excessive handling so they do not randomly extend and retract the awning.

CAUTION: Improper installation of mounting brackets may cause awning damage or personal injury. The bracket bolts must be secured to a structural stud. The brackets should be secured with lag screws as close to the center of the stud as possible. When fully extended the weight of the awning exerts significant torque on torsion bars. Failure to center bolts in structural studs will cause premature failure and result in awning collapse and possible injury.

Do not leave the awning extended during extreme weather conditions such as high wind, rain, snow and ice. The extreme weather conditions may cause the arms to break and can cause personal or damage to the property. Awntech does not take any responsibility for any weather related or improper handling of the awnings.

Never attempt to repair or disassemble the lateral extension arms. The lateral arms that support your awning are manufactured with structural grade stainless steel cables and high tension arm springs located inside the arms. Serious bodily injury or property damage can occur if attempting to install without restraining. If you have questions about this, please contact us at 800-203-7049.

## **DAMAGE DUE TO IMPROPER ANCHORING, STRONG WINDS, RAIN, SNOW OR ICE**

Awntech® Corporation does not guarantee its retractable awnings against damage that is weather related (such as strong winds, rain, snow and ice) under any circumstances. These awnings are designed to protect the customer from the sun and UV rays. They are not designed to hold snow loads, ice loads, water pooling loads or loads from debris such as leaves and falling branches.

Also, if your awning is not anchored securely, it will lift. Retractable awnings make excellent kites. If your awning starts to lift, we are not responsible and will not send free replacement parts. Securely anchoring is your responsibility. We do not provide anchors because there are many wall types. You may find the correct anchor to purchase by reviewing our installation instructions above.

When it comes to maintaining your awning, it is the best to be safe rather than sorry. This means that it is best to keep your awning retracted until you are ready to use it, and then retract it when you are finished. If you know that a strong weather front (rain or wind speeds of 30mph+) is coming, retract the awning.

# CLEANING & CARING

## NORMAL WEAR & TEAR:

Certain regions of the country are extremely hard on awnings of any kind. If you live in these areas, (High Maintenance Areas: Florida, Texas, New Mexico, Arizona, Nevada or high altitude areas) you probably already know how the sun can take a toll. Normal wear and tear is not covered in our warranty and should be expected. Damages caused by improper anchoring, strong winds, snow or ice are not considered defects. We offer replacements at affordable prices.

## CLEANING & CARING:

Beauty-Mark Awnings should be cleaned at least once a year in low maintenance areas and twice a year in high maintenance areas (see high maintenance areas above). Cleaning consists of brushing off debris with a broom, brushing on a non-detergent cleaning compound (such as ½ vinegar, ½ water), letting it sit for 20 minutes and rinsing. Regular maintenance generally means a once-a-year cleaning, with additional care if stains or soil appear. Also, remember that your awning is an exterior product. In the same way you wouldn't leave your automobile outside without washing it for very long, you'll also need to clean your Beauty-Mark® awning to preserve and extend its beauty and life. Please refer to the Cleaning and Care chart below if you acquire a stain from one of the ingredients on the list.

## CLEANING CHART FOR TYPICAL AWNING STAINS

STAIN	RECOMMENDED CLEANING SOLUTIONS
CHARCOAL	Vacuum, then liquid detergent
CHEWING GUM	Acetone
COLA	Liquid detergent
GREASE (CAR)	Acetone
IRON RUST	Oxalic or citrus acids, water
MILDEW	1 cup of bleach and 1/4 cup mild soap per gallon of water
OIL	Acetone
PAINT (LATEX) WET	Liquid detergent, water
PAINT (LATEX) DRIED	Paint, oil or grease remover
PAINT (OIL OR LACQUER)	Paint, oil or grease remover
SUNTAN LOTION	Pine Power® or pine oil detergent
TREE SAP	Turpentine, liquid detergent

# Technical Specifications

<b>MAUI<sup>®</sup></b> <b>DESTIN<sup>®</sup></b> <b>GALVESTON<sup>®</sup></b> <b>DURANGO<sup>®</sup></b> <b>TUCSON<sup>®</sup></b> <b>RICHMOND<sup>®</sup></b>	<h2 style="margin: 0;">Technical Specifications</h2>	
	<b>MANUAL</b>	<b>MOTORIZED</b>
<b>Frame Materials</b> Steel Torsion Bar Lateral Arms Cables/qty. Hardware Brackets	Powder Coated Steel – 1.5” Multi Chamber Aluminum Stainless Steel/2 per arm Stainless Steel Cast Iron/Powder Coated	Powder Coated Steel – 1.5” Multi Chamber Aluminum Stainless Steel/2 per arm Stainless Steel Cast Iron/Powder Coated
<b>Canopy Materials</b> Fabric Kind Fabric Weight Fabric Brands Fabric Choices UV Rating Water Column Permeability	100% solution dyed Acrylic 320 grams/meter <sup>2</sup> Beauty-Mark/Sunbrella 100/127 7/8 (7-8 year life – 1500 test hours) 12” Water Repellent (Teflon)	100% solution dyed Acrylic 320 grams/meter <sup>2</sup> Beauty-Mark/Sunbrella 100/127 7/8 (7-8 year life – 1500 test hours) 12” Water Repellent (Teflon)
<b>Wind Speed Allowance</b>	36 mph	36 mph
<b>Running Time From Full Charge</b>	n/a	6 Minutes
<b>Motor Location</b>	n/a	Left (default) or Right
<b>Adjustable Pitch</b> # of pitch settings max. degrees	Yes 5 80	Yes 5 80
<b>Weight</b>	80-200 lbs Depending on size	95-205 lbs Depending on size
<b>Motor Specifications</b>	<b>MANUAL</b>	<b>MOTORIZED</b>
<b>Voltage</b>	n/a	110V
<b>Frequency</b>	n/a	60HZ
<b>Input Power</b>	n/a	275W
<b>Current Intensity</b>	n/a	2.5/1.2Amps
<b>Nominal Speed</b>	n/a	14 rpm
<b>Rated Torque</b>	n/a	40nm
<b>Work Temperature</b>	n/a	-5f to 185f
<b>Remote Control</b>	<b>MANUAL</b>	<b>MOTORIZED</b>
<b>Voltage</b>	n/a	AC 110V
<b>Frequency</b>	n/a	60HZ
<b>Output Power</b>	n/a	315MHZ
<b>Distance</b>	n/a	55 yards or 164 ft.
<b>Work Temperature</b>	n/a	-5f to 185f
<b>Installation</b>	<b>MANUAL</b>	<b>MOTORIZED</b>
<b>Installation Time</b>	1-3 hours	1-3 hours
<b>Installers Required</b>	1 for installing brackets 2 for lifting awning and place the awning in the brackets	1 for installing brackets 2 for lifting awning and place the awning in the brackets
<b>Tools</b>	Electric Drill, Level, Wrenches, Power socket near position of installation for motorized.	
<b>Clearance</b>	<b>Minimum Clearance Requirements</b>	
<b>Height from Ground</b>	8'	
<b>Wall Bracket Area</b>	9.5” x length of awning for Maui, 10.5” x Length of awning for Destin	

# FABRIC SPECIFICATIONS

## BEAUTY-MARK® FABRICS

Available widths: 65 in.

Available colors: Visit [www.awntech.com](http://www.awntech.com)

### Technical Information

#### Support:

Warp yarn: SOLUTION DYED Polyester  
Weft yarn: SOLUTION DYED Polyester

#### Specifications:

<u>Specifications</u>	<u>Weight</u>	<u>Units</u>	<u>Testing Standards</u>
Weight:	290	g/m2	UNE 53243
Water column:	30	cm	ISO 811
Spray Test:	90		ISO 4920
Oil test:	5		ISO 14419
Cone test:		ml	AS 2001.2.18
		daN/5	
Warp tensile strength:	125	cm	ISO 13934
		daN/5	
Weft tensile strength:	76	cm	ISO 13934
Warp elongation at break:	36	%	ISO 13934
Weft elongation at break:	20	%	ISO 13934
Warp tearing resist.:	5	daN	DIN 5035-90
Weft tearing resist.:	3	daN	DIN 5035-90

+/- 5% tolerance in all values

#### Properties:

water repellent